

DS-MBZ942L-2X1

DS-MBZ947L-2X1

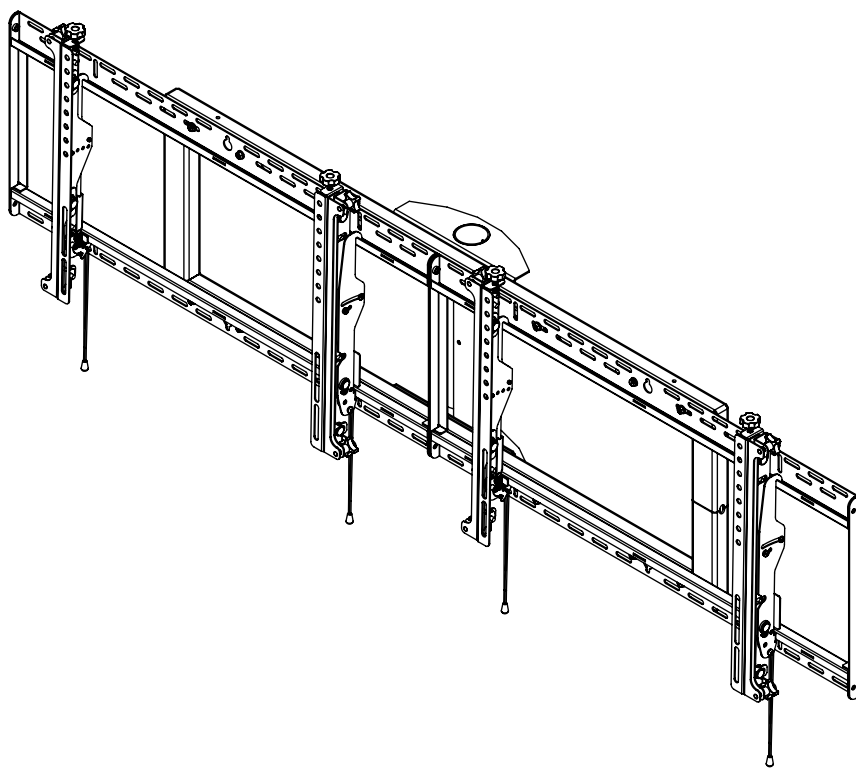
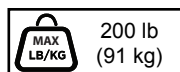
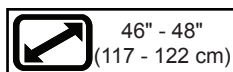
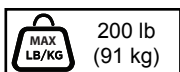
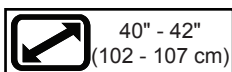

ENG	This page intentionally left blank.
ESP	Página en blanco.
FRN	Cette page a été laissée en blanc intentionnellement.
DEU	Diese Seite wurde absichtlich freigelassen.
NEL	Deze pagina is met opzet blanco gelaten.
ITL	Pagina lasciata intenzionalmente vuota.
ČEŠ	Tato strana je záměrně prázdná.
SLK	Táto strana je zámerne prázdna.
POR	Esta página foi intencionalmente deixada em branco.
TÜR	Bu sayfa özellikle boş bırakılmıştır.

▲ WARNING

ENG - Before installing make sure the supporting surface will support the combined load of the equipment and hardware. Screws must be tightly secured. Do not overtighten screws or damage can occur and product may fail. Never exceed the Maximum Load Capacity. Always use an assistant or mechanical lifting equipment to safely lift and position equipment. This product is intended for indoor use only. Use of this product outdoors could lead to product failure or personal injury. Be careful not to pinch fingers when operating the mount. For support please call customer care at 1-800-865-2112.

ENG Symbols



ENG WARNING



ENG Screws must get at least three full turns and fit snug.

ENG Tools Needed for Assembly.

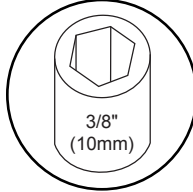
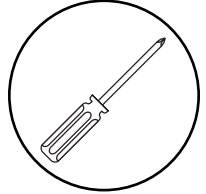
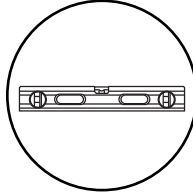

ENG Skip to step.

ENG Display center.

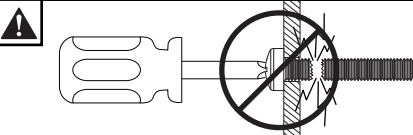

ENG Do not overtighten screws.

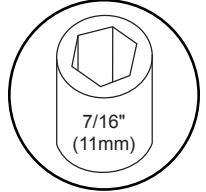

ENG To properly tighten screws: Tighten until screw head makes contact, then tighten another 1/2 turn. Do not overtighten screws.

1

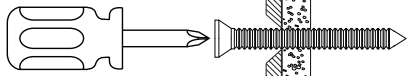

2

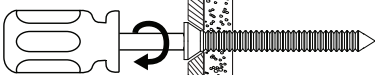

3

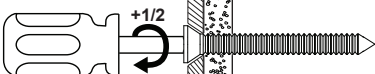

4

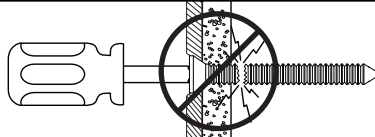

ENG Parts (Before beginning, make sure you have all parts shown below).

Description	Qty	DS-MBZ942L-2X1	DS-MBZ947L-2X1
		Part #	Part #
A wall plate	2	146-1369	146-1372
B left adapter bracket	2	146-1609	146-1609
C right adapter bracket	2	146-1608	146-1608
D retaining collar	1	1800-375	1800-375
E large washer	1	540-9432	540-9432
F M5 x 16mm phillips screw	4	520-1189	520-1189
G 1/4-20 x 1/2" phillips screw	4	510-9108	510-9108
H M6 x 12mm phillips screw	8	520-1128	520-1128
I M6 x 25mm phillips screw	8	520-1208	520-1208
J M8 x 12mm phillips screw	8	520-9571	520-9571
K M8 x 25mm phillips screw	8	520-1031	520-1031
L 5/16" flat washer	16	540-9406	540-9406
M 1/4" spacer	16	600-1215	600-1215
N 4mm allen wrench	2	560-9646	560-9646
O cable tie	6	560-9711	560-9711
P main frame	1	146-1048	146-1048
Q main post	1	146-1434	146-1434
R carriage bolt	4	520-1175	520-1175
S small washer	4	540-9440	540-9440
T nylock nut	4	530-9413	530-9413
U hex head screw	12	520-1321	520-1321
V #10 x 1/2" phillips screw	2	520-1320	520-1320
W M5 x 10mm socket pin screw	1	520-1164	520-1164
X #14 x 2-1/2" wood screw (not used)	8	-	5S1-015-C03

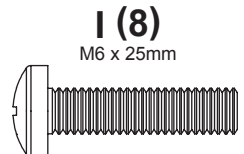
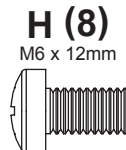
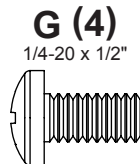
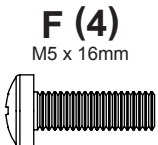
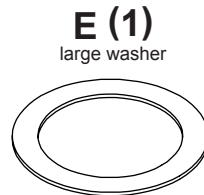
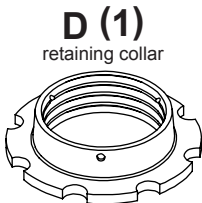
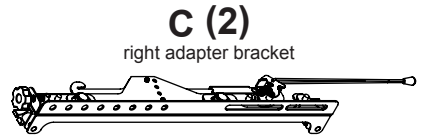
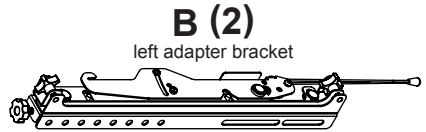
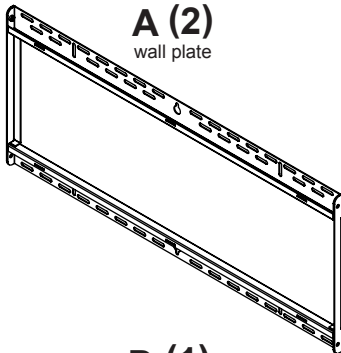

J (8)

M8 x 12mm

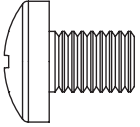

K (8)

M8 x 25mm

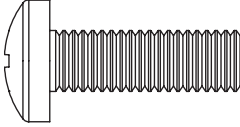

L (16)

5/16" flat washer

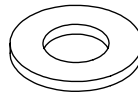

M (16)

1/4" spacer

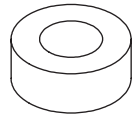

N (2)

4mm allen wrench

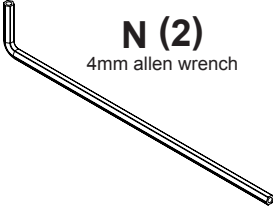

O (6)

cabl e tie

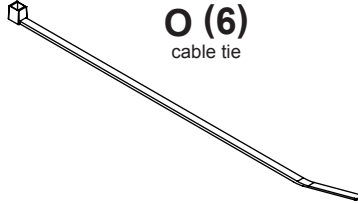

P (1)

main frame

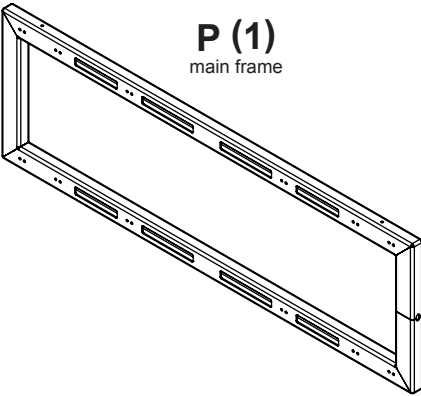

Q (1)

main post

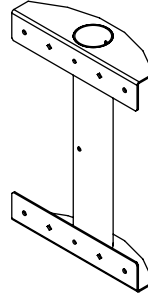

R (4)

carriage bolt

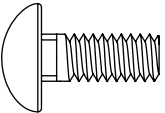

S (4)

small washer

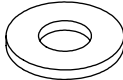

T (4)

nylock nut

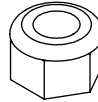

U (12)

hex head screw

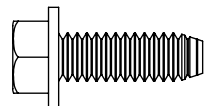

V (2)

#10 x 1/2" phillips screw

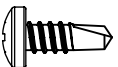

W (1)

M5 x 10mm socket pin screw

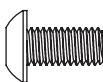

X (8)

#14 x 2-1/2" wood screw

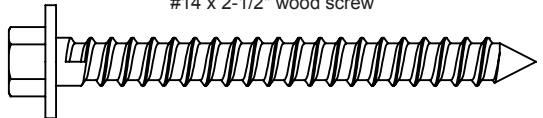

1

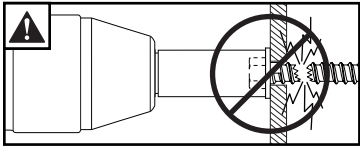
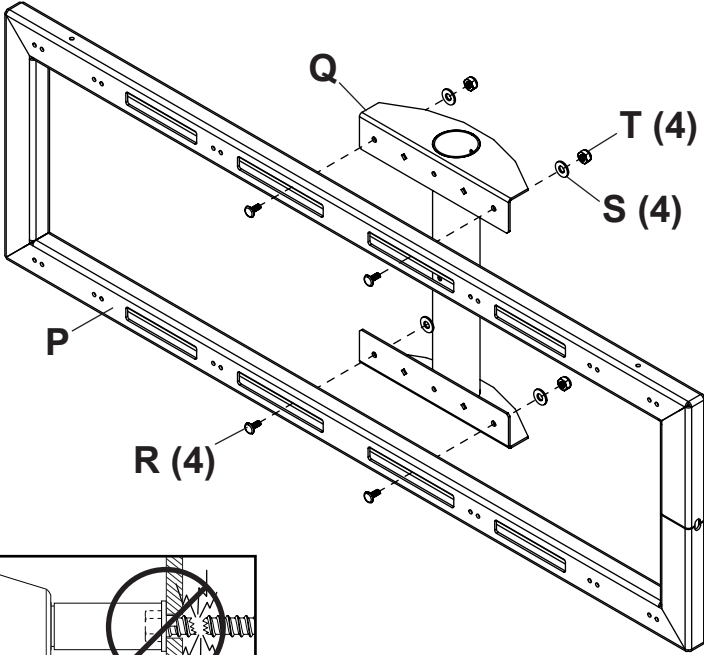
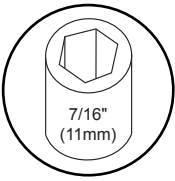
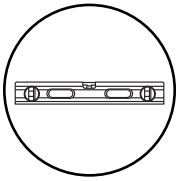

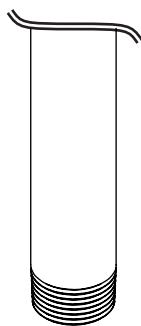
2

ENG	Pole (EXT series)
ESP	Caño (serie EXT)
FRN	Tube (gamme de EXT)
DEU	Rohr (EXT Serie)
NEL	Buis (EXT serie)
ITL	Tubo (serie EXT)
ČES	Trubička (série EXT)
SLK	Rúrka (série EXT)
POR	Tubo (série EXT)
TÜR	Boru (EXT serisi)

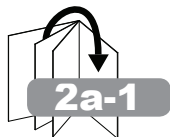
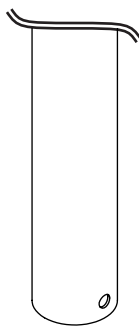
**2a-1**

ENG	Pole (MOD-P series)
ESP	Caño (serie MOD-P)
FRN	Tube (gamme de MOD-P)
DEU	Rohr (MOD-P Serie)
NEL	Buis (MOD-P serie)
ITL	Tubo (serie MOD-P)
ČES	Trubička (série MOD-P)
SLK	Rúrka (série MOD-P)
POR	Tubo (série MOD-P)
TÜR	Boru (MOD-P serisi)

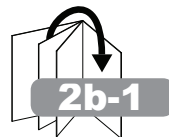
**2b-1****2a-1**

ENG	Extension pole (sold separately)
ESP	Tubo de extensión (vendidos por separado)
FRN	Tube d'extension (vendu séparément)
DEU	Verlängerungsrohr (separat verkauft)
NEL	Verlengbuis (apart verkocht)
ITL	Tubo di prolunga (venduto a parte)
ČES	Prodlužovací trubice (prodává se samostatně)
SLK	Predlžovacia trubica (predáva sa samostatne)
POR	Tubo de extensão (vendido em separado)
TÜR	Uzatma borusu (ayrica satılır)

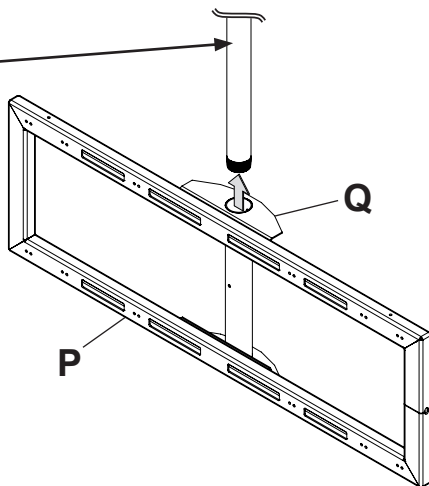
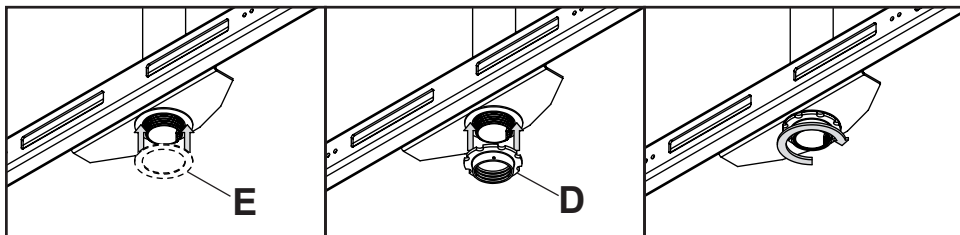
**2a-2**

2a-3

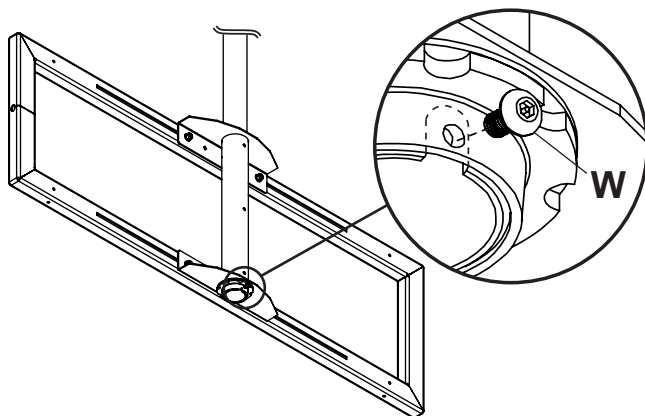
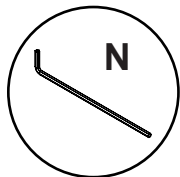

ENG Align slot of extension column with one of holes in retaining collar.

ESP Alinee la ranura de la columna de extensión con uno de los agujeros del collar de retención.

FRN Alignez la fente de la colonne d'extension sur un des trous du collier de serrage.

DEU Richten Sie den Schlitz der Verlängerungssäule mit einem der Löcher im Federteller aus.

NEL Lijn de sleuf van de verlengkolom uit met een van de gaten in de borgring.

ITL Allineare la fessura della colonna d'estensione con uno dei fori nel collare di fermo.

ČES Vyrovnajte zářez prodlužovacího sloupku s jedním z otvorů v přidržovací objímce.

SLK Zarovnajte štrbinu predlžovacieho stĺpika s jedným z otvorov v pridržiavacej objímke.

POR Alinhe a ranhura da coluna de extensão com um dos furos no colar de retenção.

TÜR Ekleme sütunu yuvasını, destek bileziğindeki deliklerden biriyle hizalayın.

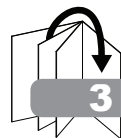

2b-1

ENG	Refer to accompanying instructions for additional information.
ESP	Consulte las instrucciones que se acompañan de información adicional.
FRN	Reportez-vous aux instructions d'accompagnement pour des informations supplémentaires.
DEU	Siehe begleitende Hinweise für weitere Informationen.
NEL	Raadpleeg de bijbehorende instructies voor meer informatie.
ITL	Fare riferimento alle istruzioni di accompagnamento per ulteriori informazioni.
ČEŠ	Viz doprovodné pokyny pro další informace.
SLK	Pozri sprievodné pokyny pre ďalšie informácie.
POR	Consulte as instruções que a acompanham para informações adicionais.
TÜR	Ek bilgi için ekteki talimatlara bakın.

2b-2

ENG	Modular extension pole (sold separately)
ESP	Tubo de extensión (vendidos por separado)
FRN	Tube d'extension (vendu séparément)
DEU	Verlängerungsrohr (separat verkauft)
NEL	Verlengbuis (apart verkocht)
ITL	Tubo di prolunga (venduto a parte)
ČEŠ	Prodlužovací trubice (prodává se samostatně)
SLK	Predĺžovacia trubica (predáva sa samostatne)
POR	Tubo de extensão (vendido em separado)
TÜR	Uzatma borusu (ayrıca satılır)

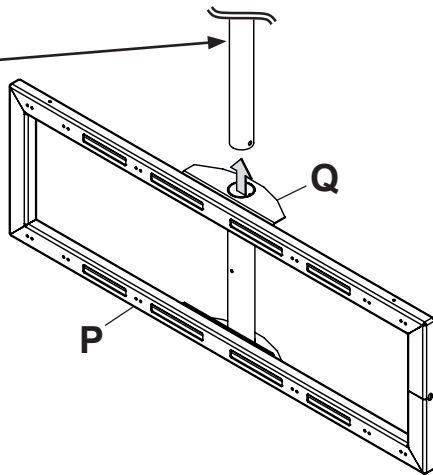

2b-3

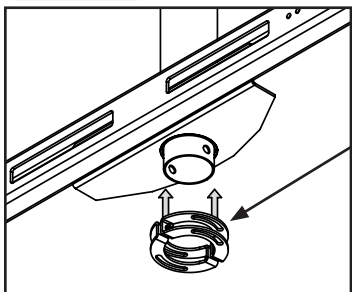

ENG	MOD-ASC (sold separately)
ESP	MOD-ASC (vendidos por separado)
FRN	MOD-ASC (vendu séparément)
DEU	MOD-ASC (separat verkauft)
NEL	MOD-ASC (apart verkocht)
ITL	MOD-ASC (venduto a parte)
ČEŠ	MOD-ASC (prodává se samostatně)
SLK	MOD-ASC (predáva sa samostatne)
POR	MOD-ASC (vendido em separado)
TÜR	MOD-ASC (ayrıca satılır)

2b-4

ENG	Tighten.
ESP	Apretar.
FRN	Serrer.
DEU	Anziehen.
NEL	Aandraaien.
ITL	Stringere.
ČEŠ	Utáhněte.
SLK	Utiahnite.
POR	Apertar.
TÜR	Sıkmak.

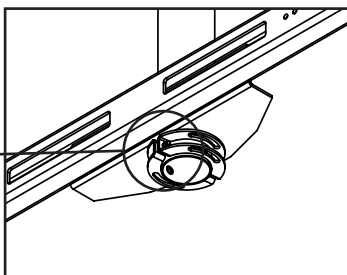
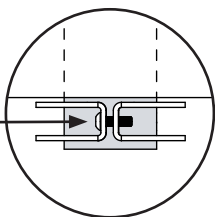

2b-5

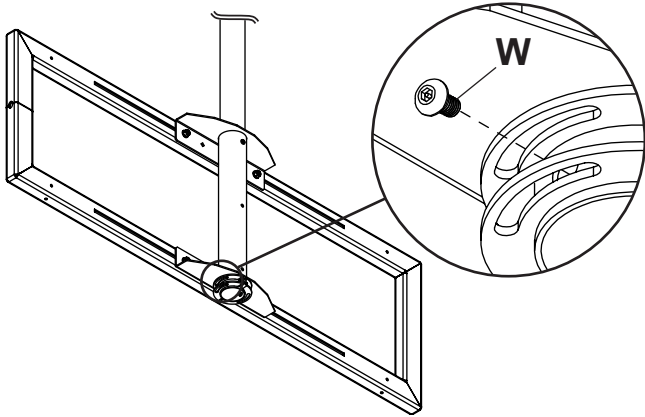
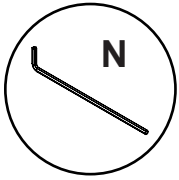

ENG	Refer to accompanying instructions for additional information.
ESP	Consulte las instrucciones que se acompañan de información adicional.
FRN	Reportez-vous aux instructions d'accompagnement pour des informations supplémentaires.
DEU	Siehe begleitende Hinweise für weitere Informationen.
NEL	Raadpleeg de bijbehorende instructies voor meer informatie.
ITL	Fare riferimento alle istruzioni di accompagnamento per ulteriori informazioni.
ČES	Viz doprovodné pokyny pro další informace.
SLK	Pozri sprievodné pokyny pre ďalšie informácie.
POR	Consulte as instruções que a acompanham para informações adicionais.
TÜR	Ek bilgi için ekteki talimatlara bakın.

3

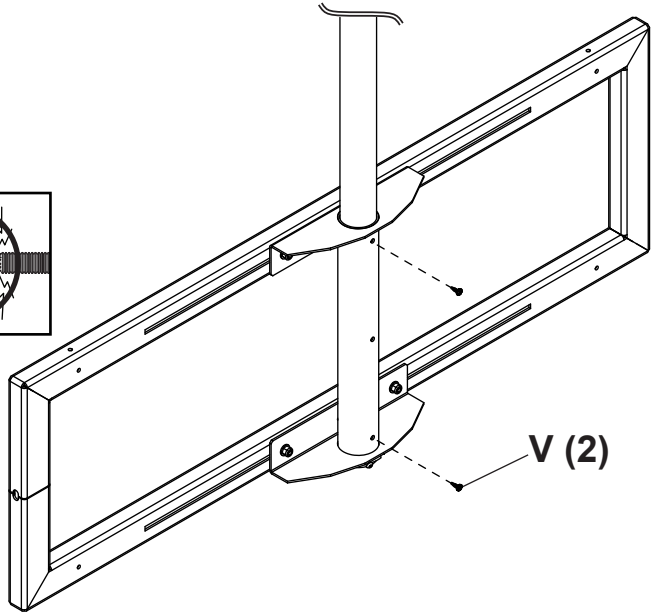
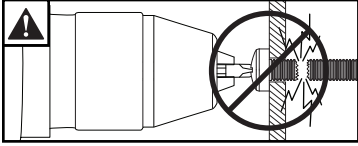

V (2)

4-1

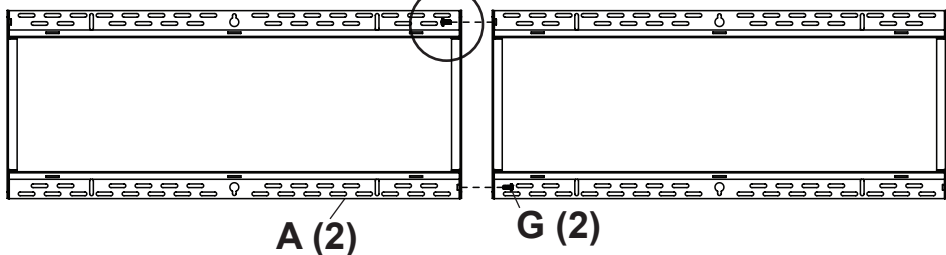
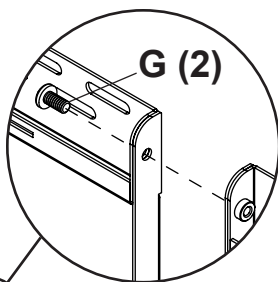
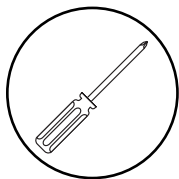

4-2

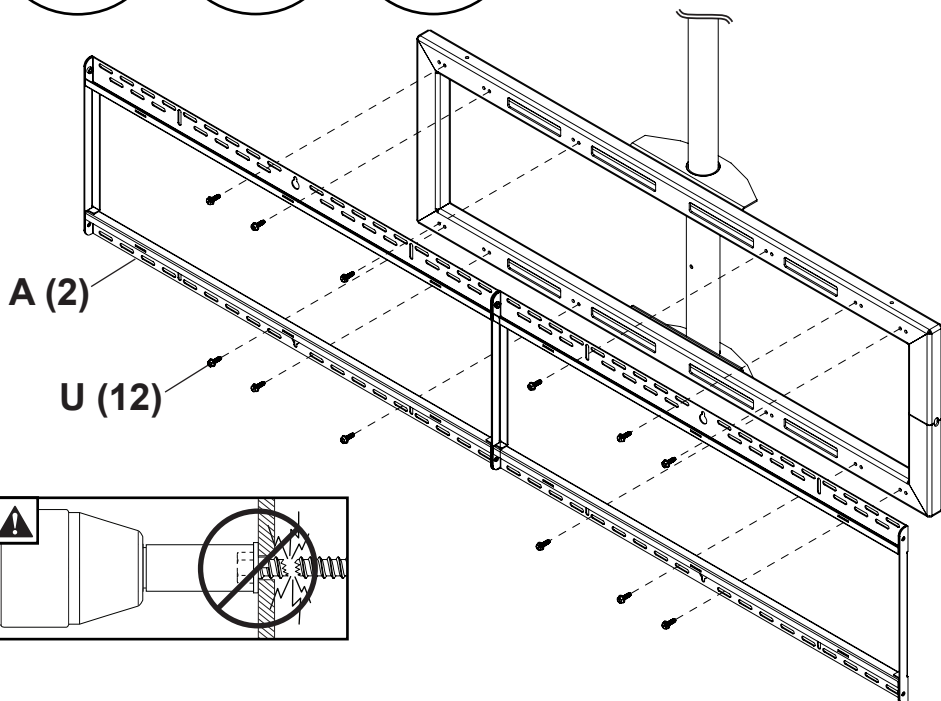
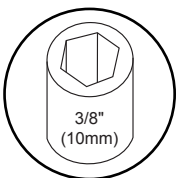
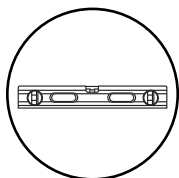

5-1

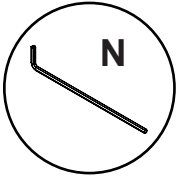

ENG	Optional.
ESP	Opcional.
FRN	Facultatif.
DEU	Fakultativ.
NEL	Facultatief.
ITL	Opzionale.
ČES	Voltitelné.
SLK	Voltiteľ'né.
POR	Opcional.
TÜR	İsteğe Bağlı.

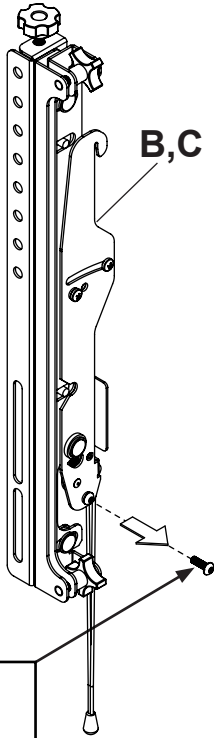

ENG	Remove.
ESP	Quite.
FRN	Retirez.
DEU	Entfernen.
NEL	Verwijderen.
ITL	Rimuovere.
ČES	Odstranit.
SLK	Odstrániť.
POR	Remova.
TÜR	Çıkartın.

5-2

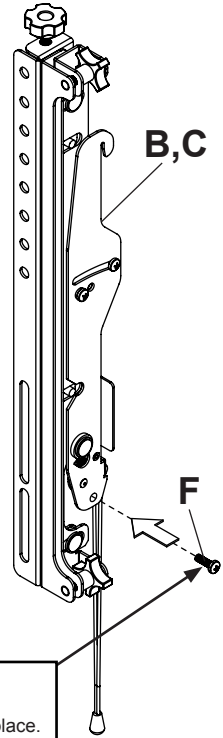
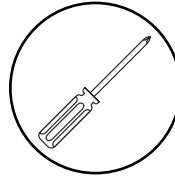

ENG	Replace.
ESP	Remplace.
FRN	Remettez en place.
DEU	Ersetzen.
NEL	Vervangen.
ITL	Rimettere a posto.
ČES	Znova nasadit.
SLK	Znova nasadiť.
POR	Coloque novamente.
TÜR	Değiştirin.

6

- ENG** Center adapter brackets vertically on back of screen.
- ESP** Centre verticalmente los soportes en la pantalla.
- FRN** Centrez les supports à la verticale de l'écran.
- DEU** Richten Sie die Halterungen senkrecht mittig an der Bildschirm.
- NEL** Centre de beugels verticaal op de van het scherm.
- ITL** centra le staffe verticalmente sul dello schermo.
- ČES** vycentrujte konzoly svisle na zadní obrazovky.
- SLK** vycentrujte konzoly zvisle na obrazovky.
- POR** centre os suportes verticalmente no do ecrã.
- TÜR** dirsekleri ekranın arkasına dikey olarak ortalayın.

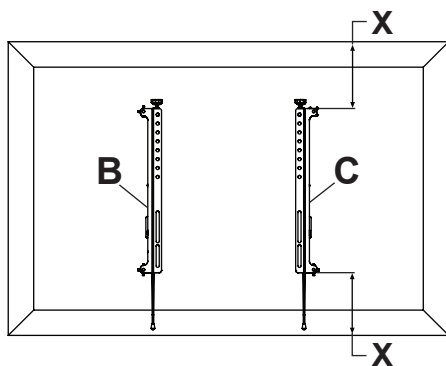

7

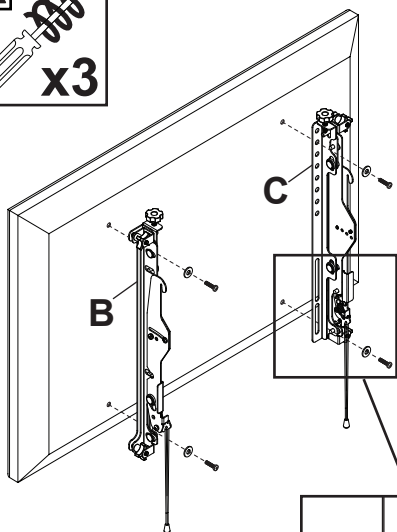
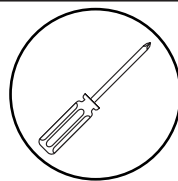

- ENG** Use of spacers and washers is optional.
- ESP** Uso de espaciadores y arandelas opcional.
- FRN** Facultatif utilisation d'entretoises de rondelles.
- DEU** Fakultativ verwendung von abstandhaltern und Waschmaschinen.
- NEL** Facultatief gebruik van tussenringen en ringen.
- ITL** Uso opzionale di distanziatori e rondelle.
- ČES** Voltitelné použití rozpěr distančních podložek.
- SLK** Voltiteľné použitie rozpierok distančných podložiek.
- POR** Opcional utilize espaçadores e arruelas.
- TÜR** Ayırıcıların isteğe bağlı kullanımı ve yıkayıcı.

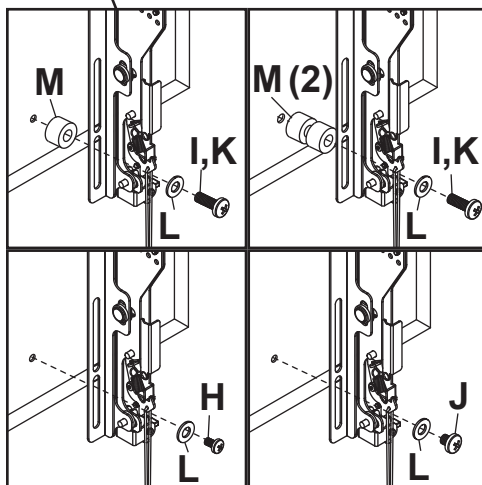

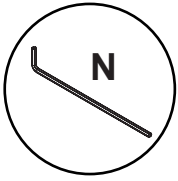
8-1

ENG	Loosen.
ESP	Afloje
FRN	Desserrez
DEU	Lösen
NEL	Losdraaien
ITL	Allentare
CES	Uvolnit
SLK	Uvoľniť
POR	Desaperte
TÜR	Gevşetin

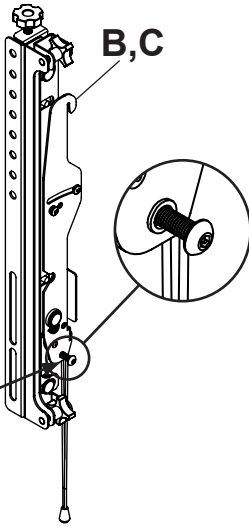
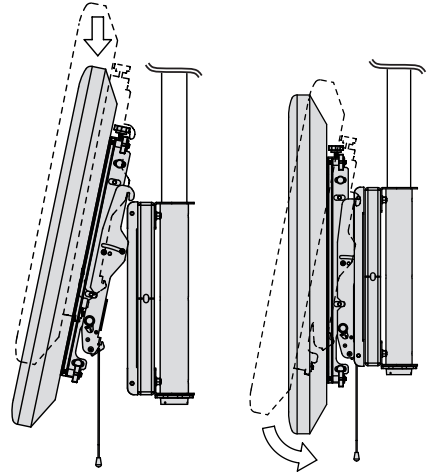
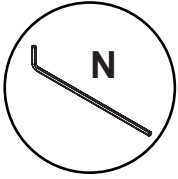
**8-2****8-3**

ENG	Tighten.
ESP	Apretar.
FRN	Serrer.
DEU	Anziehen.
NEL	Aandraaien.
ITL	Stringere.
CES	Utáhněte.
SLK	Utiahnite.
POR	Apertar.
TÜR	Sıkmak.

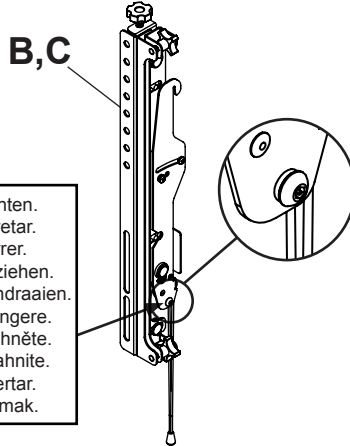
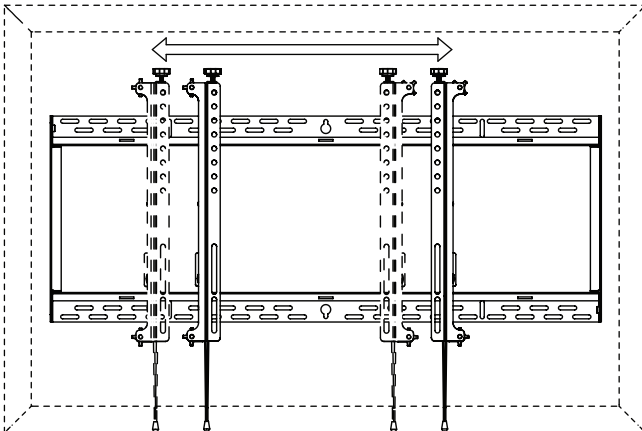
**9**

10

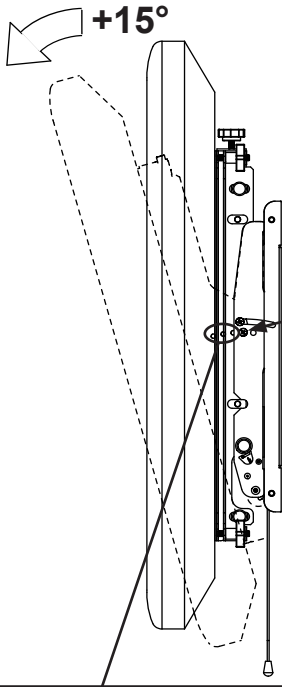

ENG	Loosen, adjust, retighten
ESP	Afloje, ajuste, vuelva a apretar
FRN	Desserrez, réglez, resserrez
DEU	Lösen, einstellen, erneut anziehen
NEL	Losdraaien, aanpassen, opnieuw aandraaien
ITL	Allentare, regolare, stringere di nuovo
ČEŠ	Uvolnit, nastavit, znova přitáhnout
SLK	Uvolniť, nastaviť, znova pritiahnúť
POR	Desaperte ajuste, aperte novamente
TÜR	Gevşetin, ayarlayın, tekrar sıkın

<p>Pre-set tilt positions of 0°, 5°, 10° or 15°.</p> <p>Ángulos de inclinación predeterminados de 0°, 5°, 10° o 15°.</p> <p>Angles d'inclinaison pré-réglés de 0°, 5°, 10° ou 15°.</p> <p>Neigungsstellungen von 0°, 5°, 10° oder 15° voreingestellt.</p> <p>Vooraf ingestelde kantelposities van 0°, 5°, 10° of 15°.</p> <p>Inclinazioni prefissate: 0°, 5°, 10° o 15°.</p> <p>Předvolené polohy sklonu: 0°, 5°, 10° nebo 15°.</p> <p>Predvolené polohy sklonu: 0°, 5°, 10° alebo 15°.</p> <p>Posições de inclinação predefinidas de 0°, 5°, 10° ou 15°.</p> <p>Önceden ayarlanmış eğim konumları 0°, 5°, 10° veya 15°.</p>		<table border="1"> <tr><td>ENG</td><td>Tighten.</td></tr> <tr><td>ESP</td><td>Apretar.</td></tr> <tr><td>FRN</td><td>Serrer.</td></tr> <tr><td>DEU</td><td>Anziehen.</td></tr> <tr><td>NEL</td><td>Aandraaien.</td></tr> <tr><td>ITL</td><td>Stringere.</td></tr> <tr><td>ČEŠ</td><td>Utáhněte.</td></tr> <tr><td>SLK</td><td>Utiahnite.</td></tr> <tr><td>POR</td><td>Apertar.</td></tr> <tr><td>TÜR</td><td>Sıkma.</td></tr> </table>	ENG	Tighten.	ESP	Apretar.	FRN	Serrer.	DEU	Anziehen.	NEL	Aandraaien.	ITL	Stringere.	ČEŠ	Utáhněte.	SLK	Utiahnite.	POR	Apertar.	TÜR	Sıkma.
ENG	Tighten.																					
ESP	Apretar.																					
FRN	Serrer.																					
DEU	Anziehen.																					
NEL	Aandraaien.																					
ITL	Stringere.																					
ČEŠ	Utáhněte.																					
SLK	Utiahnite.																					
POR	Apertar.																					
TÜR	Sıkma.																					

11

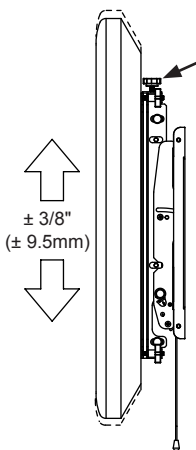

ENG	Adjust
ESP	Ajuste
FRN	Réglez
DEU	Einstellen
NEL	Aanpassen
ITL	Regolare
ČEŠ	Nastavit
SLK	Nastaviť
POR	Ajuste
TÜR	Ayarlayın

± 1/4" (± 6mm)

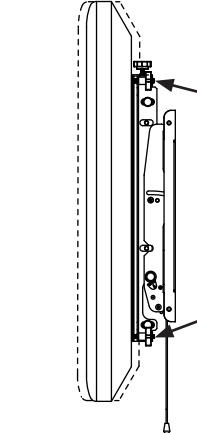

ENG	Adjust
ESP	Ajuste
FRN	Réglez
DEU	Einstellen
NEL	Aanpassen
ITL	Regolare
ČEŠ	Nastavit
SLK	Nastaviť
POR	Ajuste
TÜR	Ayarlayın

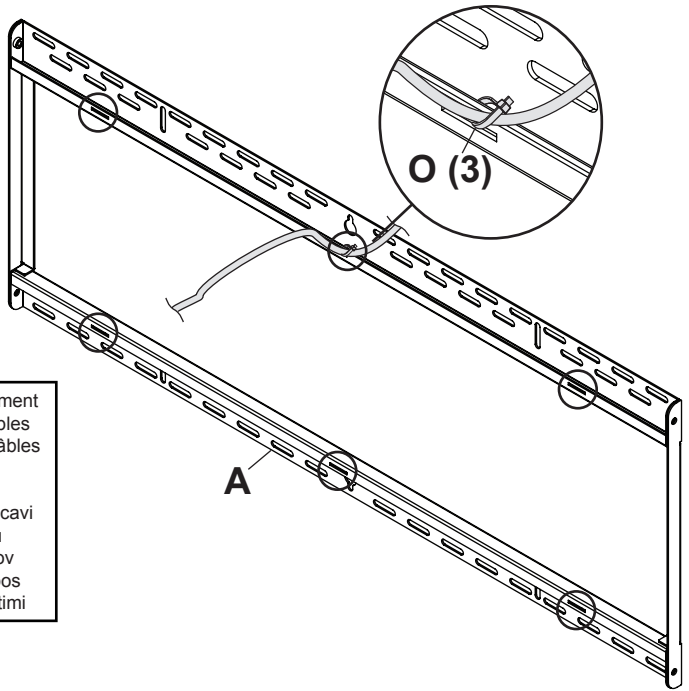

ENG	Optional: cable management
ESP	Opcional: manejo de cables
FRN	Facultatif: gestion des câbles
DEU	Fakultativ: Kabelführung
NEL	Facultatief: kabelbeheer
ITL	Opzionale: gestione dei cavi
ČEŠ	Volitelné: vedení kabelů
SLK	Voliteľné: vedenie káblov
POR	Opcional: gestão de cabos
TÜR	İsteğe Bağlı: kablo yönetimi

13-1

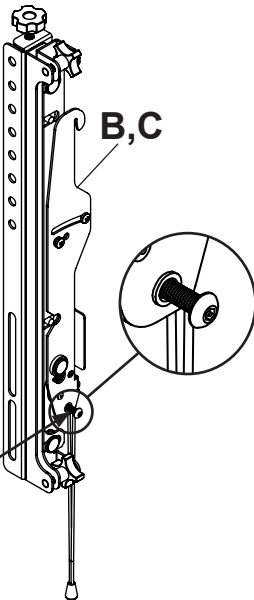
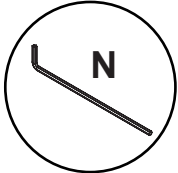

ENG	Loosen.
ESP	Afloje
FRN	Desserrez
DEU	Lösen
NEL	Losdraaien
ITL	Allentare
ČEŠ	Uvolnit
SLK	Uvoľniť
POR	Desaperte
TÜR	Gevşetin

13-2

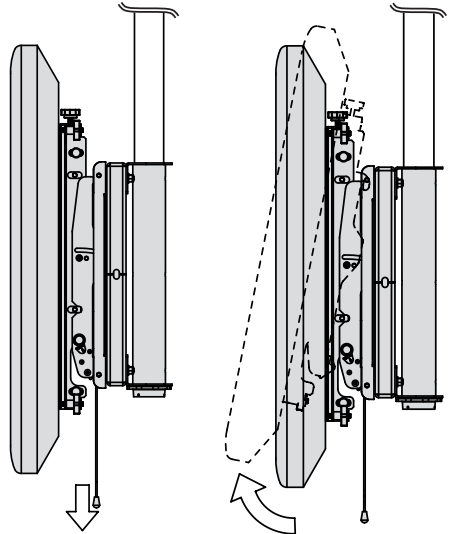

14-1

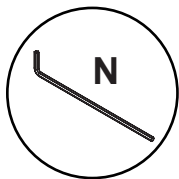

ENG	Optional.
ESP	Opcional.
FRN	Facultatif.
DEU	Fakultativ.
NEL	Facultatief.
ITL	Opzionale.
ČES	Voltitelné.
SLK	Voltiteľ'né.
POR	Opcional.
TÜR	İsteğe Bağlı.

▲ WARNING

ENG	Kickstand is for maintenance only
ESP	El pie de apoyo es para realizar tareas de mantenimiento solamente
FRN	Le support intégré est destiné uniquement à l'entretien
DEU	Ausklappbarer Abstandhalter dient nur zu Wartungszwecken
NEL	Steun is uitsluitend bedoeld voor gebruik tijdens onderhoud
ITL	Il cavalletto è solo per la manutenzione
ČES	Stojanček slúži len na údržbu
SLK	Stojanček slúži len na údržbu
POR	O suporte basculante destina-se apenas a tarefas de manutenção
TÜR	Dayanak yalnızca bakım amacıyla kullanılır

ENG	Loosen.
ESP	Afloje
FRN	Desserrez
DEU	Lösen
NEL	Losdraaien
ITL	Allentare
ČES	Uvolnit
SLK	Uvoľniť
POR	Desaperte
TÜR	Gevşetin

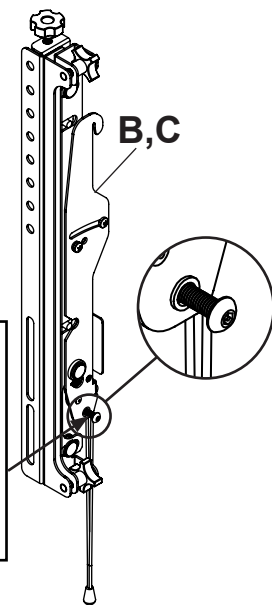

14-2

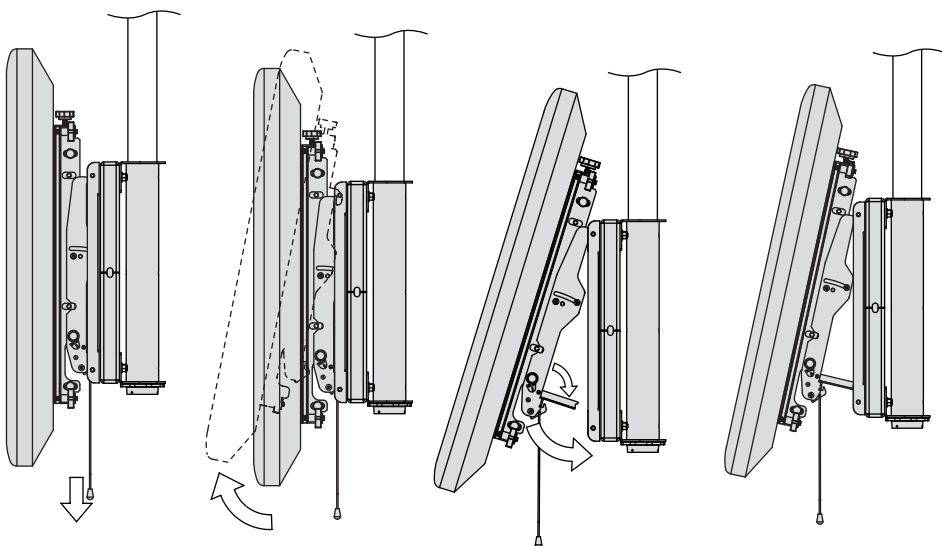

ENG	This page intentionally left blank.
ESP	Página en blanco.
FRN	Cette page a été laissée en blanc intentionnellement.
DEU	Diese Seite wurde absichtlich freigelassen.
NEL	Deze pagina is met opzet blanco gelaten.
ITL	Pagina lasciata intenzionalmente vuota.
ČEŠ	Tato strana je záměrně prázdná.
SLK	Táto strana je zámerne prázdná.
POR	Esta página foi intencionalmente deixada em branco.
TÜR	Bu sayfa özellikle boş bırakılmıştır.

ENG	This page intentionally left blank.
ESP	Página en blanco.
FRN	Cette page a été laissée en blanc intentionnellement.
DEU	Diese Seite wurde absichtlich freigelassen.
NEL	Deze pagina is met opzet blanco gelaten.
ITL	Pagina lasciata intenzionalmente vuota.
ČEŠ	Tato strana je záměrně prázdná.
SLK	Táto strana je zámerne prázdná.
POR	Esta página foi intencionalmente deixada em branco.
TÜR	Bu sayfa özellikle boş bırakılmıştır.

LIMITED FIVE-YEAR WARRANTY

Peerless Industries, Inc. ("Peerless-AV") warrants to original end-users that each Peerless-AV® mounting product will be free from defects in material and workmanship, under normal use, for the applicable warranty period (from date of the original installation of the product). At its option, Peerless-AV will repair or replace, or refund the purchase price of, any product which fails to conform with this warranty.

Any implied warranty of merchantability or fitness for a particular purpose shall be limited to the period of the express warranty set forth below.

In no event shall Peerless-AV be liable for incidental or consequential damages, whether or not secured by a security device which may be included with the product.

Some states do not allow limitations on how long an implied warranty lasts, or the exclusion of incidental or consequential damages, so the above limitation and/or the above exclusion may not apply to you.

This warranty does not cover damage caused by incorrect selection, installation or the failure to follow Peerless-AV instructions or warnings when installing, using or storing the product.

This warranty gives specific legal rights, and you may also have other rights which vary from state to state. To make a warranty claim in North America, contact Peerless-AV customer care at 1-800-865-2112. See complete global warranty information for regions outside North America at www.peerless-av.com/en-uk/customer-care/warranties-returns.

GARANTÍA LIMITADA DE CINCO AÑOS

Peerless Industries, Inc. (Peerless-AV) les garantiza a los usuarios finales originales que ningún producto de montaje de Peerless-AV® tendrá defectos de materiales o de manufactura, en condiciones de uso normal, durante el período de garantía correspondiente (a partir de la fecha de instalación original del producto). Queda a la discreción de Peerless-AV, reparar, reemplazar o reembolsar el precio de compra de cualquier producto que no cumpla esta garantía.

Toda garantía implícita de comerciabilidad o de idoneidad para un propósito en particular quedará limitada al período de vigencia de la garantía explícita indicada en lo siguiente.

Peerless-AV no tendrá responsabilidad, en caso alguno, de daños y perjuicios incidentales o indirectos, ya sea que el producto esté o no esté asegurado con un dispositivo de seguridad que se haya incluido con el producto.

Algunos Estados no permiten que se establezcan limitaciones en relación con el período de duración de una garantía implícita ni la exclusión de daños y perjuicios incidentales o indirectos, de manera que es posible que la limitación o la exclusión expuesta en lo anterior no sea pertinente a usted.

Esta garantía no cubre daños causados por selecciones o instalaciones inadecuadas o por no seguir las instrucciones o las advertencias de Peerless-AV al instalar, utilizar o guardar el producto.

Esta garantía concede derechos específicos creados por ley y es posible que usted, además, tenga otros derechos que varíen de acuerdo con el Estado donde se encuentre. Para presentar una reclamación de acuerdo con la garantía en América del Norte, llame a Servicio al Cliente de Peerless al 1-800-865-2112. Vea la información completa de la garantía global pertinentes a regiones fuera de América del Norte en www.peerless-av.com/en-uk/customer-care/warranties-returns.

GARANTIE LIMITÉE DE CINQ ANS

Peerless Industries, Inc. (« Peerless-AV ») garantit aux utilisateurs finaux initiaux que chaque produit de montage de Peerless-AV® sera exempt de défauts de matériau et de fabrication, selon une utilisation normale, pendant la période de garantie applicable (à compter de la date d'installation initiale du produit). À sa discrétion, Peerless-AV réparera ou remplacera tout produit qui n'est pas conforme à cette garantie, ou en remboursera le prix d'achat.

Toute garantie implicite de qualité marchande ou d'aptitude à une fin particulière doit se limiter à la période de garantie expresse indiquée ci-dessous.

Peerless-AV ne peut en aucun cas être tenu responsable de dommages accidentels ou consécutifs, que le produit ait été fixé ou non à l'aide d'un dispositif de sécurité inclus dans l'emballage.

Certains États n'autorisent pas la limitation de la durée d'une garantie implicite ou l'exclusion de dommages accidentels ou consécutifs, de sorte que la limite ci-dessus et/ou l'exclusion ci-dessus peuvent ne pas s'appliquer à votre situation.

La présente garantie ne couvre pas les dommages causés par une sélection erronée, une mauvaise installation ou le non-respect des instructions ou des avertissements de Peerless-AV lors de l'installation, de l'utilisation ou de l'entreposage du produit.

La présente garantie confère des droits légaux précis et vous pouvez aussi jouir d'autres droits qui varient d'un État à l'autre. Pour présenter une réclamation au titre de la garantie en Amérique du Nord, communiquez avec le service à la clientèle de Peerless-AV au 1-800-865-2112. Consulter les renseignements complets sur la garantie mondiale pour les régions à l'extérieur de l'Amérique du Nord à www.Peerless-Av.com/en-uk/customer-care/warranties-returns.

BESCHRÄNKTEN FÜNFJÄHRIGEN GARANTIE

Peerless Industries, Inc. („Peerless-AV“) übernimmt gegenüber den ursprünglichen Endnutzern die Gewährleistung, dass alle Peerless-AV®-Montageprodukte unter normalen Einsatzbedingungen für die zutreffende Garantiefrist (ab Datum der ursprünglichen Installation des Produkts) frei von Material- und Verarbeitungsfehlern sind. Peerless-AV repariert oder ersetzt nach eigenem Ermessen ein Produkt, das dieser Garantie nicht entspricht, oder erstattet den Kaufpreis dafür.

Die Dauer einer stillschweigenden Garantie der handelsüblichen Qualität oder Eignung für einen bestimmten Zweck ist auf den Zeitraum der unten angegebenen ausdrücklichen Garantie beschränkt.

Auf keinen Fall haftet Peerless-AV für Neben- oder Folgeschäden, unabhängig davon, ob das Produkt durch eine eventuell mitgelieferte Sicherheitsvorrichtung gesichert war oder nicht.

In einigen Staaten ist die Beschränkung des Zeitraums für stillschweigende Garantien oder der Ausschluss von Neben- oder Folgeschäden nicht zulässig, sodass die oben aufgeführte Einschränkung und/oder der oben genannte Ausschluss auf Sie möglicherweise nicht zutreffen.

Diese Garantie gilt nicht bei Schäden, die aufgrund falscher Auswahl, Installation oder Nichtbefolgung von Peerless-AV-Anweisungen oder -Warnhinweisen bei der Installation, Verwendung oder Lagerung des Produkts entstehen.

Diese Garantie verleiht Ihnen bestimmte gesetzliche Rechte, und Sie verfügen u. U. über weitere Rechte, die sich von Staat zu Staat unterscheiden können. Um einen Garantieanspruch in Nordamerika geltend zu machen, wenden Sie sich bitte an den Kundendienst von Peerless-AV unter der Rufnummer 1-800-865-2112. Die vollständigen Garantieinformationen für Gebiete außerhalb von Nordamerika sind unter www.peerless-av.com/en-uk/customer-care/warranties-returns zu finden.

BEPERKTE GARANTIE VAN 5 JAAR

Peerless Industries, Inc. („Peerless-AV“) garandeert originele eindgebruikers dat elk Peerless-AV® montageproduct bij normaal gebruik vrij is van materiaal- en fabricagefouten gedurende de geldende garantieperiode (vanaf de datum van de originele installatie van het product). Naar diens keuze zal Peerless-AV elk product dat niet aan deze garantie voldoet, repareren of vervangen, of de aankoopprijs ervan vergoeden.

Elke geïmpliceerde garantie van verkoopbaarheid of geschiktheid voor een bepaald doel blijft beperkt tot de hieronder vermelde periode van uitdrukkelijke garantie.

In geen geval is Peerless-AV aansprakelijk voor incidentele of gevolgschade, of het product al dan niet beveiligd is door een beveiligingsmiddel dat mogelijk bij het product is meegeleverd.

In sommige staten zijn beperkingen van de duur van een geïmpliceerde garantie, of de uitsluiting van incidentele of gevolgschade niet toegestaan, dus mogelijk zijn de hierboven vermelde beperkingen en/of uitsluitingen niet op u van toepassing.

Deze garantie dekt geen schade die is veroorzaakt door onjuiste selectie of installatie of het niet volgen van de instructies of waarschuwingen van Peerless-AV bij de installatie, het gebruik of de opslag van het product.

Deze garantie geeft u specifieke wettelijke rechten, en mogelijk hebt u ook andere rechten die tussen staten onderling verschillen. Voor het indienen van een garantieclaim in Noord-Amerika, dient u contact op te nemen met de klantendienst van Peerless-AV op 1-800-865-2112. Zie de volledige algemene informatie over garantie voor regio's buiten Noord-Amerika op www.peerless-av.com/en-uk/customer-care/warranties-returns.

GARANZIA QUINQUENNALE LIMITATA

Peerless Industries, Inc. („Peerless-AV“) garantisce agli utenti finali originali che ogni prodotto di montaggio Peerless-AV® sarà privo di difetti nei materiali e nella lavorazione, in condizioni d'uso normali, per il periodo di garanzia concesso (dalla data dell'installazione originale del prodotto). A sua discrezione, Peerless-AV sostituirà o riparerà, o restituirà il prezzo pagato se il prodotto non è conforme a questa garanzia.

Ogni garanzia implicita di commerciabilità o idoneità ad uno scopo particolare non sarà più lunga del periodo di validità della garanzia come espressamente indicate più sotto.

In nessun caso, Peerless-AV sarà responsabile di danni incidentali o consequenziali, siano o no garantiti da un dispositivo di sicurezza che potrebbe essere incluso con il prodotto.

Alcuni Stati vietano la limitazione della durata della garanzia implicita, o l'esclusione dei danni incidentali o consequenziali; pertanto, la suddetta limitazione o esclusione potrebbe non riguardare chiunque.

La presente garanzia non copre danni causati da scelta o installazione non corretta del prodotto, o dall'inosservanza delle istruzioni o avvertenze fornite da Peerless-AV in sede d'installazione, uso o rimessa del prodotto.

Questa garanzia conferisce diritti di legge specifici; vi possono essere altri diritti variabili da Stato a Stato. Per fare una richiesta in garanzia in Nord America, contattare il servizio clienti Peerless-AV telefonando al numero 1-800-865-2112. Per informazioni complete sulla garanzia internazionale relative ad aree esterne al Nord America, visitare www.peerless-av.com/en-uk/customer-care/warranties-returns.

OMEZENÁ PĚTILETÁ ZÁRUKA

Společnost Peerless Industries, Inc. ("Peerless-AV") zaručuje prvním koncovým uživatelům, že každý montážní výrobek Peerless-AV® bude při běžném používání po příslušnou záruční dobu (ode dne první instalace výrobku) bez materiálních a výrobních vad. Podle rozhodnutí zákazníka společnost Peerless-AV opraví, vymění či vrátí kupní cenu u jakéhokoliv výrobku, u kterého dojde k porušení této záruky.

Jakákoliv předpokládaná záruka přednosti nebo vhodnosti pro konkrétní použití bude omezená na dobu vyjádřené záruky, jak je uvedeno níže.

Společnost Peerless-AV nebude za žádných okolností zodpovědná za nahodilé či následné škody, ať již byly či nebyly zajištěny bezpečnostním zařízením, které může být součástí tohoto výrobku.

V některých státech nesmí být předpokládaná záruka časově omezena, stejně jako není možné vynechat následné škody. Výše uvedená omezení se vás proto nemusí týkat.

Tato záruka se nevztahuje na škodu způsobenou nesprávným výběrem, instalací nebo ignorováním pokynů či varování společnosti Peerless-AV během instalace, používání nebo skladování výrobku.

Tato záruka uvádí konkrétní zákonná práva. Můžete však mít i jiná práva, která se mohou mezi jednotlivými státy lišit. Pokud chcete uplatnit záruku v Severní Americe, zavolejte na linku zákaznické péče společnosti Peerless-AV na telefonní číslo 1-800-865-2112. Kompletní celosvětové platné informace o záruce pro oblasti mimo Severní Ameriku najdete na adrese: www.peerless-av.com/en-uk/customer-care/warranties-returns.

OBMEDZENÁ PÄTROČNÄ ZÄRUKA

Spoločnosť Peerless Industries, Inc. ("Peerless-AV") zaručuje pôvodným koncovým používateľom, že každý montážny výrobok Peerless-AV® bude pri bežnom používaní počas príslušnej záručnej doby (od dátumu pôvodnej inštalácie výrobku) bez poškodenia materiálu a spracovania. Spoločnosť Peerless-AV podľa vlastného uváženia opraví alebo nahradí každý výrobok, ktorý nie je v súlade s touto zárukou, alebo vráti kúpnu cenu tohto výrobku.

Každá implicitná záruka obchodovateľnosti alebo vhodnosti na konkrétny účel je obmedzená na obdobie výslovnej záruky uvedenej nižšie.

Spoločnosť Peerless-AV nenesie v žiadnom prípade zodpovednosť za náhodné alebo následné škody, bez ohľadu na zabezpečenie bezpečnostným zariadením, ktoré môže byť súčasťou výrobku.

Niektoré štáty nepovoľujú obmedzenia týkajúce sa dĺžky trvania implicitnej záruky alebo vylúčenia náhodných alebo následných škôd, takže vyššie uvedené obmedzenie a/alebo vyššie uvedené vylúčenie sa na vás nemusí vzťahovať.

Táto záruka sa nevzťahuje na škody spôsobené nesprávnym výberom, inštaláciou alebo nedodržaním pokynov alebo upozornení spoločnosti Peerless-AV pri inštalácii, používaní alebo skladovaní výrobku.

Touto zárukou sa poskytujú osobitné zákonné práva a môžete mať aj iné práva, ktoré sa v jednotlivých štátoch líšia. Ak si chcete uplatniť nárok na záruku v Severnej Amerike, kontaktujte zákaznický servis spoločnosti Peerless-AV na čísle 1-800-865-2112. Informácie o kompletných celosvetových zárukách pre oblasti mimo Severnej Ameriky nájdete na stránke www.peerless-av.com/en-uk/customer-care/warranties-returns.

GARANTIA LIMITADA DE CINCO ANOS

A Peerless Industries, Inc. ("Peerless-AV") garante aos usuários finais originais que cada produto de montagem Peerless-AV® estará livre de defeitos de material e de fabricação, sob uso normal, pelo período de garantia aplicável (a partir da data da primeira instalação do produto). A seu critério, a Peerless-AV reparará ou substituirá (ou reembolsará o preço de compra de) qualquer produto que não esteja em conformidade com esta garantia.

Qualquer garantia implícita de mercado ou adequação a uma finalidade específica será limitada ao período da garantia expressa estabelecida abaixo.

Em caso algum, a Peerless-AV será responsável por danos incidentais ou consequenciais, protegidos ou não por um dispositivo de segurança que possa estar incluído no produto.

Alguns estados não permitem limitações sobre o tempo de duração de uma garantia implícita ou a exclusão ou limitação de danos incidentais ou consequentes, portanto, as limitações ou exclusões acima podem não se aplicar a si.

Esta garantia não cobre danos causados por seleção incorreta, instalação ou falha em seguir as instruções ou advertências da Peerless-AV ao instalar, usar ou armazenar o produto.

Esta garantia concede direitos legais específicos, e você também pode ter outros direitos que variam de estado para estado. Para fazer uma reclamação de garantia na América do Norte, entre em contato com o atendimento ao cliente da Peerless-AV pelo número 1-800-865-2112. Veja as informações completas sobre a garantia global para regiões fora da América do Norte em www.peerless-av.com/en-uk/customer-care/warranties-returns.

BEŞ YILLIK SINIRLI GARANTİ

Peerless Industries, Inc. ("Peerless-AV"), orijinal son kullanıcıları, her bir Peerless-AV® montaj ürünü için, geçerli garanti süresi boyunca (ürünün ilk kurulumundan itibaren) malzeme ve işçilik hatalarına karşı garanti verir. Peerless-AV, uygun görüldüğü durumlarda, hatalı ürünleri onaracak veya değiştirecek ya da ürünü bedelsiz iade edecektir.

Ticarette elverişlilik veya belirli bir amaca uygunluk gibi her türlü dolaylı garanti, aşağıda belirtilen açık garanti süresiyle sınırlıdır.

Aygit ürüne birlikte verilen bir sabitleme cihazıyla sabitlenmiş olsun veya olmasın, Peerless-AV, hiçbir durumda kaza sonucu veya dolaylı olarak meydana gelen hasarlardan sorumlu değildir.

Bazı eyaletler dolaylı garantisinin süresine dair kısıtlama getirilmesine ya da kaza sonucu veya dolaylı meydana gelen hasarların hariç tutulmasına izin vermemektedir; o nedenle yukarıdaki kısıtlama ve/veya hariç tutma sizin için geçerli olmayabilir.

Bu garanti hatalı seçim, hatalı kurulum ya da ürünün kurulumu, kullanımı veya saklanması sırasında Peerless-AV talimatlarının veya uyarılarının dikkate alınmamasından kaynaklanan hasarları kapsamaz.

Bu garanti size belirli yasal haklar verir ve eyalete göre değişen başka haklar da geçerli olabilir. Kuzey Amerika'daki garanti ile ilgili başvuruda bulunmak için 1-800-865-2112 numaralı telefonla Peerless AV müşteri hizmetlerini arayın. Kuzey Amerika dışındaki bölgeler için kapsamlı küresel garanti bilgilerinizi www.peerless-av.com/en-uk/customer-care/warranties-returns adresinde bulabilirsiniz.



Peerless-AV
2300 White Oak Circle
Aurora, IL 60502
Email: tech@peerlessmounts.com
Ph: (800) 865-2112
Fax: (800) 359-6500
www.peerless-av.com

© 2019, Peerless Industries, Inc.

Peerless-AV Europe
Unit 3 Watford Interchange,
Colonial Way, Watford, Herts,
WD24 4WP, United Kingdom
Customer Care
44 (0) 1923 200 100
www.peerless-av.com

© 2019, Peerless Industries, Inc.

Peerless-AV de Mexico
Ave de las Industrias 413
Parque Industrial Escobedo
Escobedo N.L. Mexico 66062
Servicio al Cliente
01-800-849-65-77
www.peerless-av.com

© 2019, Peerless Industries, Inc.